

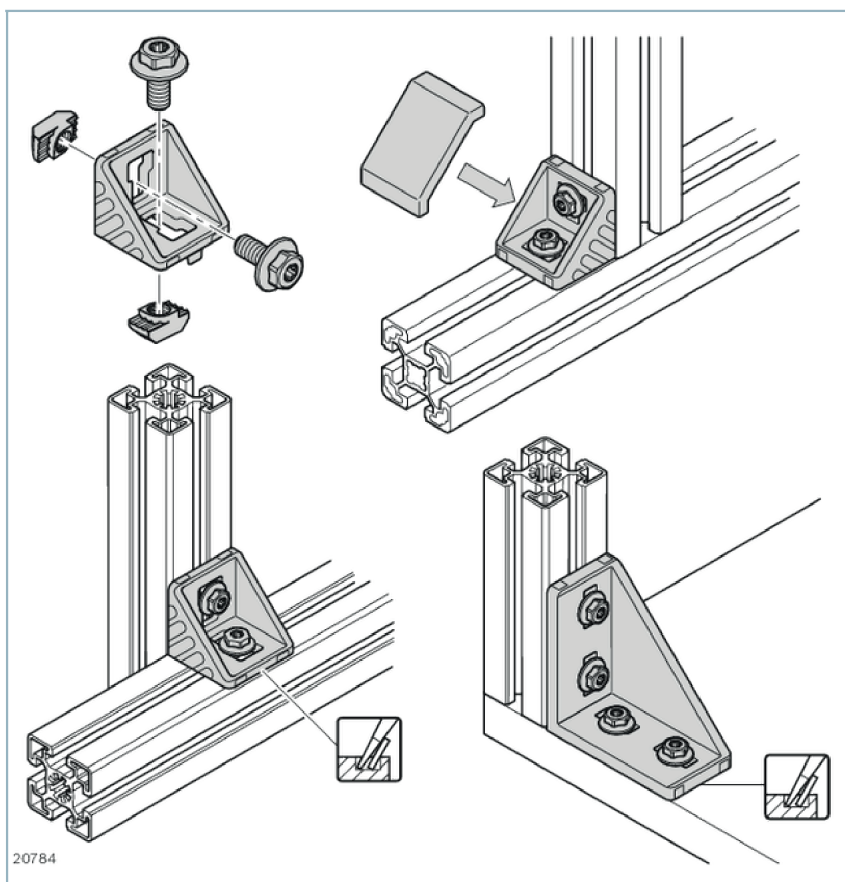

- Para montaje en paneles o a través de la ranura las orejetas de centrado se pueden romper fácilmente
- Versión DesignLINE con plata pintura especial (RAL 9006) para especiales diseño de alta calidad
- Pieza intermedia para posicionar ángulos en la siguiente ranura más grande
- Tapa protectora para evitar suciedad, señal gris en las variantes (RAL 7004) y ESD negro (RAL 9005)
- Procesamiento de perfiles: No requerido disponible

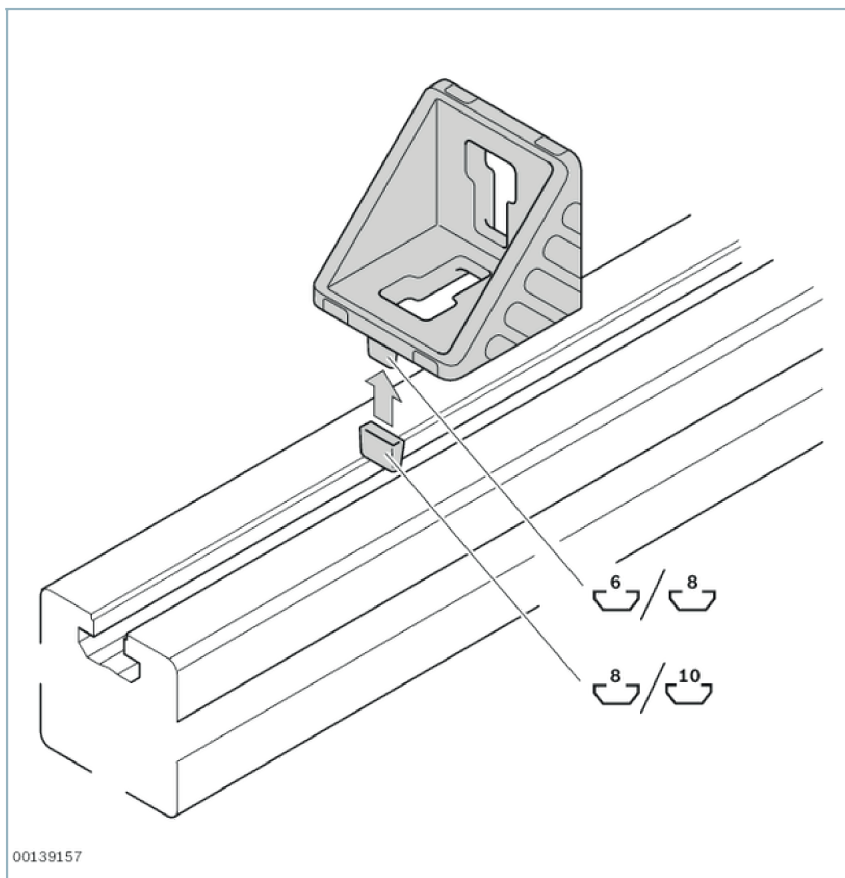





Typ				
30 / 30	1250 N	25 Nm	75 Nm	-

Typ				
30/30	1250 N	25 Nm	75 Nm	-

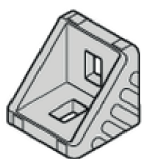
30/30

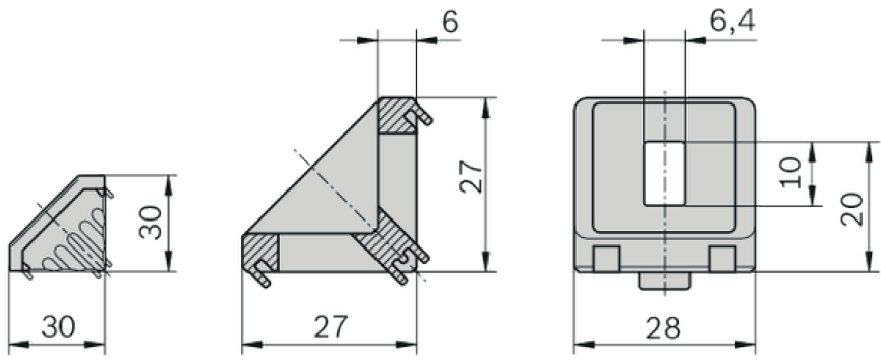
00109415

FS2	FS3	FS4
 	 	 