

 [www.randrade.com](http://www.randrade.com) - TLF. 986 600 286

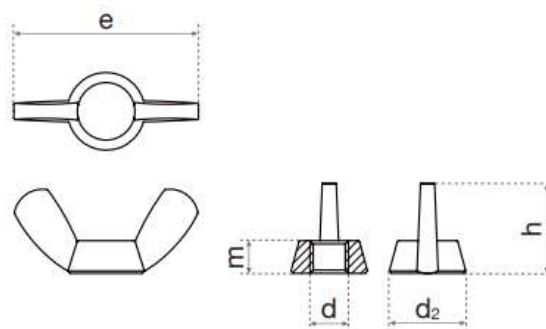

d	M3	M4	M5	M6	M8
e	17.6	17.6	22	27	30.3
d2	7.8	7.8	9.5	11.9	13.5
h	8.6	8.6	10.5	13	14.8
m	2.9	2.9	4	5	5.4

d	M10	M12	M14	M16	M20
e	35.5	47.5	66	66	66.5
d2	15.3	20.5	25.5	25.5	29.3
h	17.3	22.1	30.8	30.8	31.2
m	6.3	8	10.6	10.6	12.2

**COMPOSICIÓN QUÍMICA (en %)**

	C	Mn	Si	P	S	Cr	Ni	Mo	Cu
Mínimo	--	--	--	--	--	16,00	10,00	2,000	--
Máximo	0,080	2,000	1,000	0,045	0,030	18,50	15,00	3,000	4,000

**CARACTERÍSTICAS MECÁNICAS**

	Mínimo	Máximo
Resistencia Tracción – N/mm <sup>2</sup>	700,00000	--
Limite Elasticidad – N/mm <sup>2</sup>	450,00000	--